

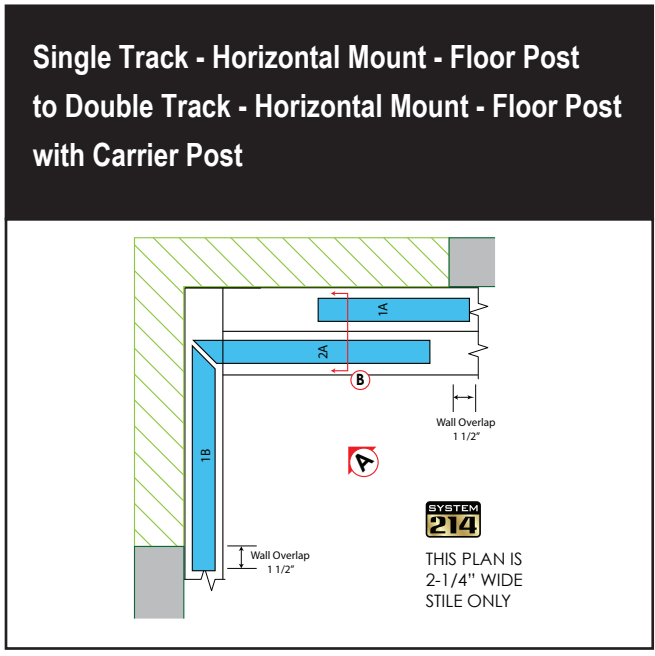

MONACO Installation Instructions - Mitred Panels - Butted Tracks

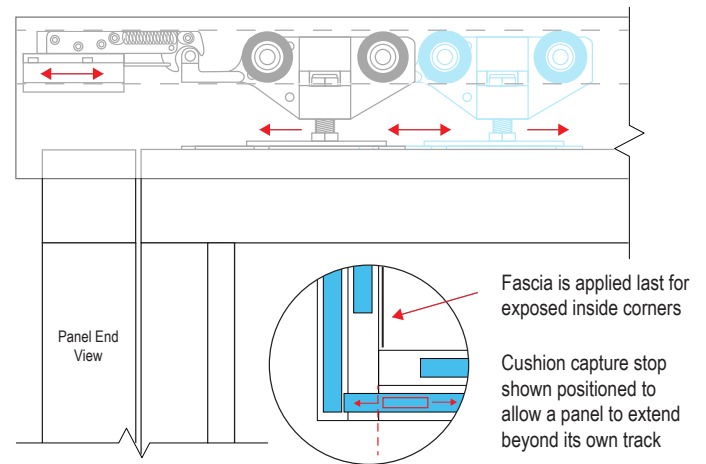

Monaco cushion capture stops are provided for both fully open and fully closed panel positions. In the fully closed position the stops aren't always at the end of the track. They can be positioned further ahead or further back to retract or extend a panel as needed. In a corner application this allows for the two outermost panels to meet together when closed.

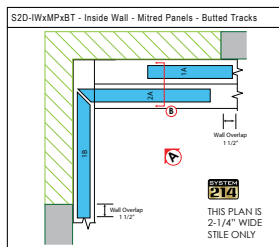
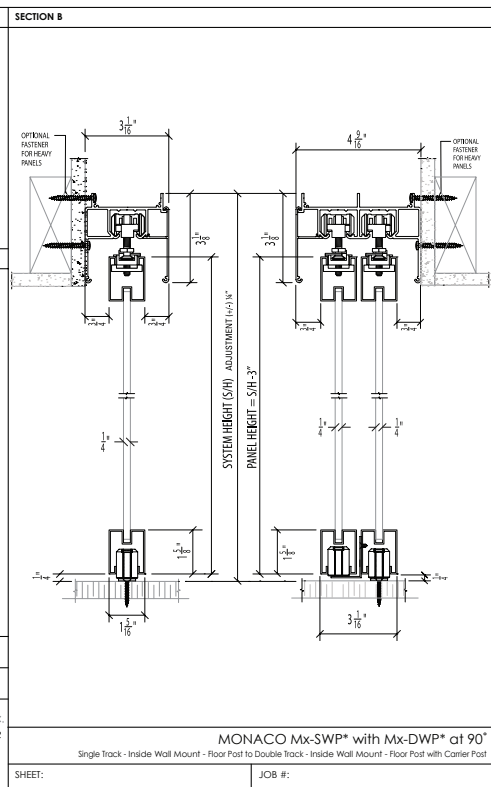
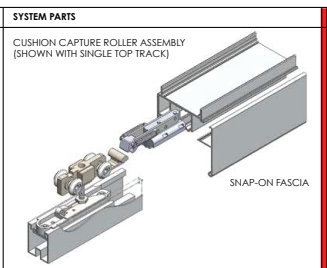
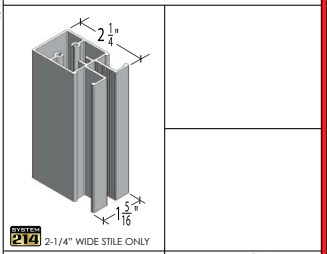

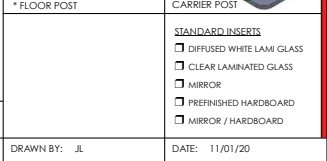
<p>SZD-IWxMPxBT - Inside Wall - Mitred Panels - Butted Tracks</p>  <p>ELEVATION A</p>	<p>SECTION B</p>  <p>OPTIONAL FASTENER FOR HEAVY PANELS</p> <p>OPTIONAL FASTENER FOR HEAVY PANELS</p> <p>SYSTEM HEIGHT (SHT) ADJUSTMENT (+/-) 1/8"</p> <p>PANEL HEIGHT = 5H - 3"</p> <p>MONACO Mx-SWP* with Mx-DWP* at 90° Single Track - Inside Wall Mount - Floor Post to Double Track - Inside Wall Mount - Floor Post with Carrier Post</p>	<p>SYSTEM PARTS</p> <p>CUSHION CAPTURE ROLLER ASSEMBLY (SHOWN WITH SINGLE TOP TRACK)</p>  <p>SNAP-ON FASCIA</p>  <p>SYSTEM 214 2-1/4" WIDE STILE ONLY</p>  <p>* FLOOR POST</p>  <p>CARRIER POST</p> <p>STANDARD INSERTS</p> <ul style="list-style-type: none"> <input type="checkbox"/> DIFFUSED WHITE LAMI GLASS <input type="checkbox"/> CLEAR LAMINATED GLASS <input type="checkbox"/> MIRROR <input type="checkbox"/> PREFINISHED HARDBOARD <input type="checkbox"/> MIRROR / HARDBOARD 	<p>OPTIONAL PARTS</p> <p><input type="checkbox"/> BLACK ANODIZED FINISH</p> <p><input type="checkbox"/> TRACK END CAP</p> <p><input type="checkbox"/> LOCK</p> <p><input type="checkbox"/> EDGE PULL</p> <p>SPECIAL INSERTS</p> <ul style="list-style-type: none"> <input type="checkbox"/> POLAR WHITE GLASS <input type="checkbox"/> BLACK GLASS <input type="checkbox"/> CUSTOMER SUPPLIED INSERT <input type="checkbox"/> DIVISION BARS
<p>SEE INSTALLATION INSTRUCTIONS FOR CORNER DETAILS</p> <p>PROJECT:</p> <p>ARCHITECT:</p> <p>Riviera rivieraglassdividers.com</p> <p>ALLIANCE GLASS DOORS INC. Surrey, BC, Canada, V3W 1A2 T: 604.501.2588 F: 604.501.1608</p>	<p>SHEET: _____ JOB #: _____</p>	<p>DRAWN BY: JL DATE: 11/01/20</p>	<p>CHECKED BY: DL</p>

PLEASE NOTE: "x" in the product code refers to the stile options - Standard = "TT" = "214" = "M58"

Monaco - System Components

- 1 - Main Track
- 2 - Snap on Fascia
- 3 - Track End Cap
- 4 - Cushion Capture
- 5 - Roller
- 6 - Roller Bumper
- 7 - Adjusting Bolt
- 8 - Hanger Lock
- 9 - Rail Cap
- 10 - Floor Post
- 11 - Carrier Post

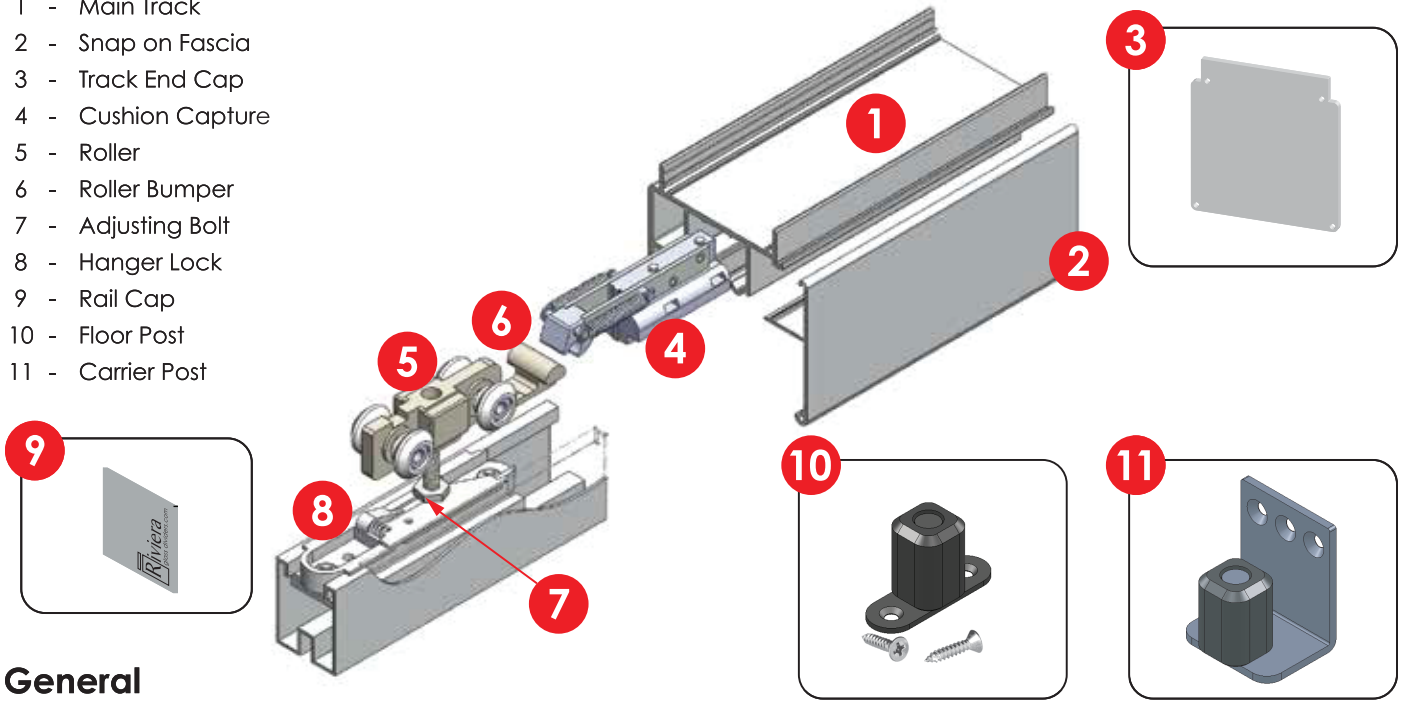

General

- A - "T" Stile
- B - Moderno 58 with D Shaped Pull **
- C - System 214 Wide 2 1/4" Stile **
- D - Sidelite Shoe
- E - System 214 Lock
- F - System 214 Edge Pull

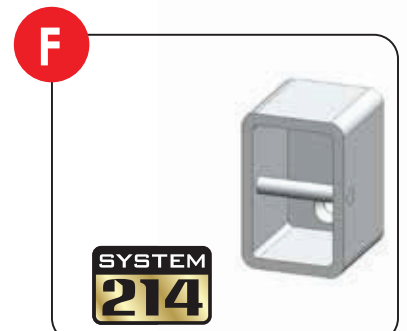
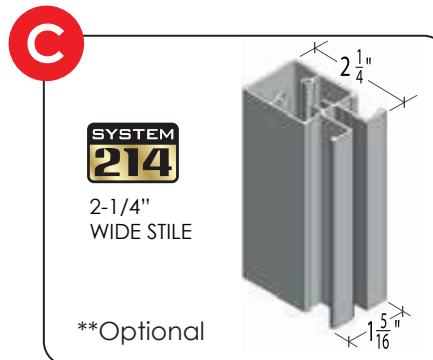
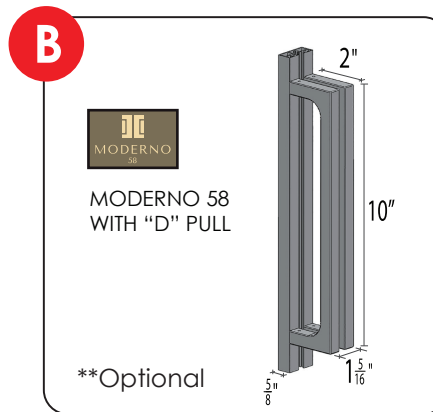
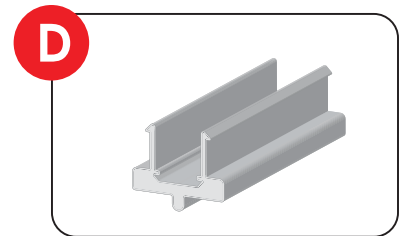
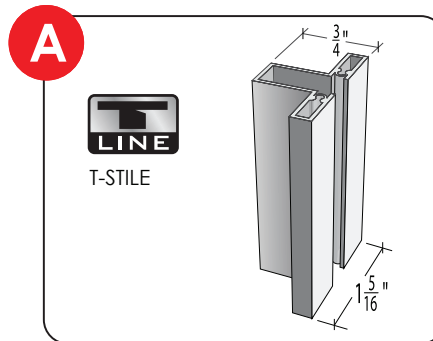
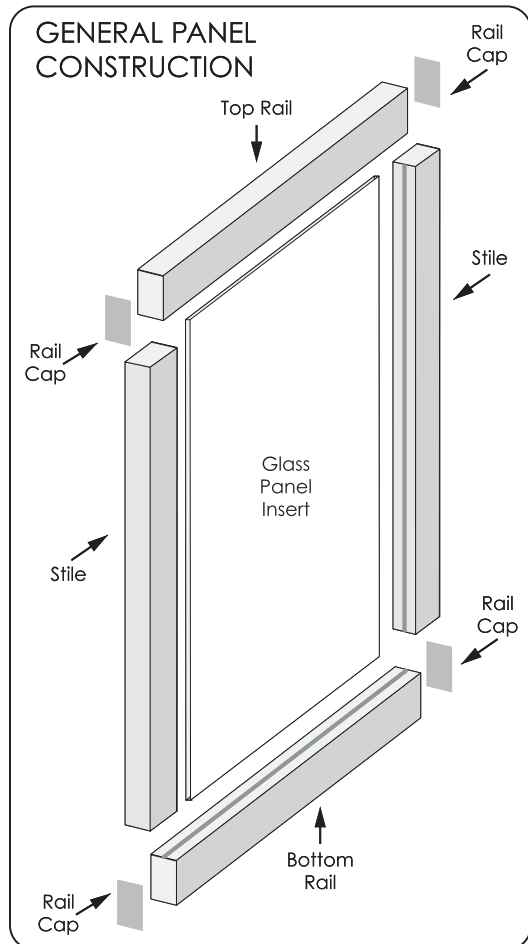

IMPORTANT: Read these instructions completely before beginning any installation. Once the product is at the opening site and tools and parts are set up and ready to go, each panel should be able to be installed in 20 - 30 minutes.

A Install Top Track Main Portion

NOTE: Top of top track = panel height plus 3" (+/- 1/4") from finished floor. Additionally, panels should overlap side walls by 1 1/2" on each side. Refer to Wall Mount form at www.rivieraglassdividers.com

- 1** Measure track and using a power miter box (chop saw) trim both main track and fascia to length as required. Allow a minimum 1 1/2" overlap on each side wall when slider is in the fully closed position. You will also want to ensure that there is enough length of track for the slider to completely clear the opening when it is in the fully open position.
- 2** Position track on the wall to allow for wall overlap when slider is in the fully closed position.
- 3** Mounting screws **MUST** be located into solid backing and spaced at approximately 24" - 32" centres including a fastener at each end of the track. Mark drill locations on the inside of the fixed fascia and drill fastener holes using the bottom drill line provided. **Tip:** To aid in track levelling drill fastener holes slightly oversized (5/16") to fit the HEX drive screws provided.
- 4** Install cushion capture and rollers into track ensuring that the roller bumper faces the cushion capture hook. Level and mount the top track to the wall above opening.

DON'T INSTALL FASCIA AT THIS TIME

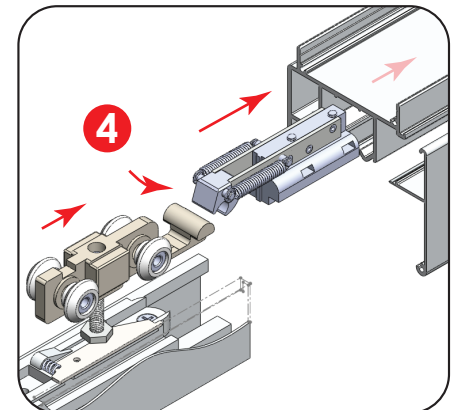
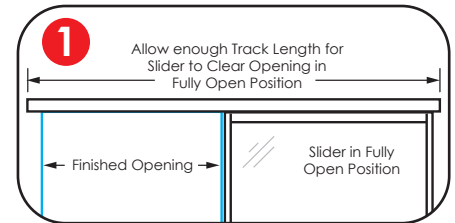
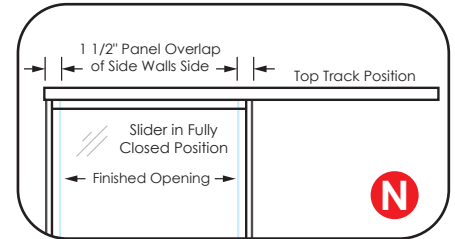

B Install Floor Post

- 5** Screw the FLOOR POST to the floor in front of the wall that the panel will slide over when open, so the leading EDGE of the post is 1/8" back from the vertical edge of the opening. The Post should be centred vertically under top roller track.

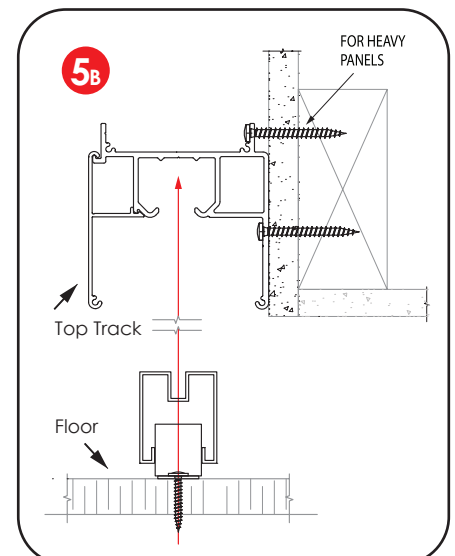
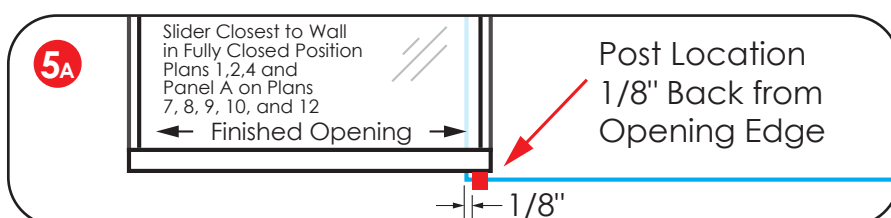

B Install Floor Post cont.

5₁ ALTERNATE INSTALLATION: If it is not desirable to screw into the floor, a CARRIER POST may be wall applied. Position as above however Carrier Post MUST be spaced 1/2" - 5/8" away from the Top Track mounting surface by fastening the Carrier Post to the baseboard or by using shims.

IMPORTANT NOTE: Sliding Panel Rail Cap should never come in contact with the Floor Post or Carrier Post. (See "PANEL ADJUSTMENT")

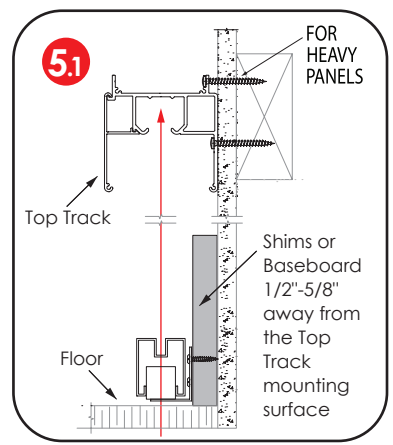

C Install the Panel

6 Ensure the Hanger Locks that are pre-installed in the panel rail are at the top of the panel(s).

SPECIAL NOTE: To achieve a panel stopping position in line with the end of the Cushion Capture assembly, the Roller Adjusting Bolt should engage the Hanger Lock spring 4 9/16" from the the end of the panel.

7 Set the panel rail over the floor or carrier post(s) at the floor.

8 Lift the panel(s) up and engage each roller adjusting bolt head into its hanger lock by pushing bolt against spring lock until it latches. Adjust roller bolt vertically using the combination wrench/screwdriver tool provided, to adjust floor clearance and vertically align panels with wall edge.

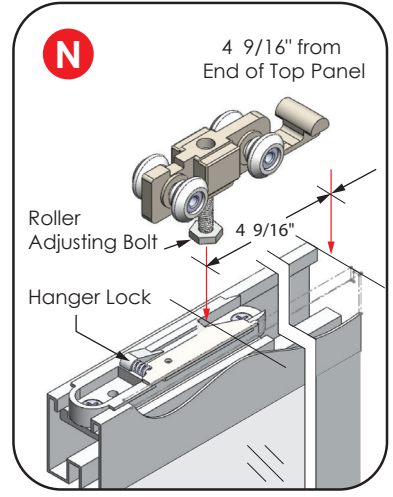

D Panel Adjustment

9 *Adjust Cushion Capture and Hanger Lock horizontally such that the Bottom Rail Cap never comes in contact with the Floor or Carrier Posts.*

10 Panel stopping location can be fine tuned by loosening the two screws in the cushion capture mechanism and moving to desired position along the track.

11 Further adjustment can be achieved by adjusting the Hanger Lock position in the top rail. Loosen the two clamp screws using an 90 degree angled Philips screw driver.

12 Hook removable Fascia over main track and snap into place to top track.

13 Install track end caps to exposed track ends with the four #4 - 1/2" screws provided, using the wrench/screwdriver tool provided. (#0-Yellow Robertson drive tip)

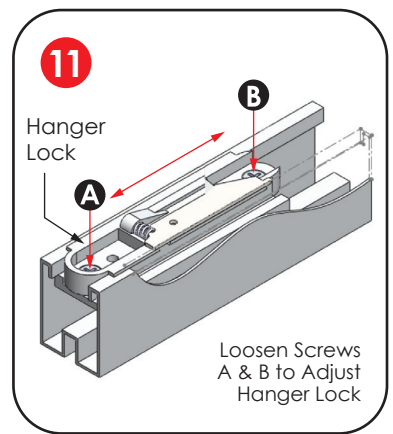
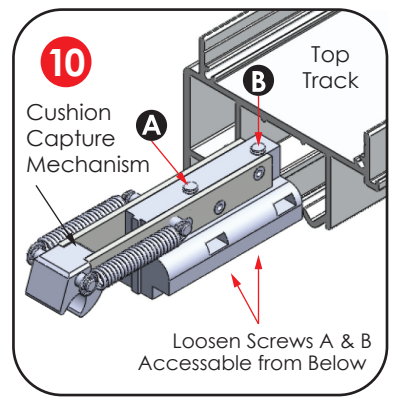

IMPORTANT: Read these instructions completely before beginning any installation. Once the product is at the opening site and tools and parts are set up and ready to go, each panel should be able to be installed in 20 - 30 minutes.

A Install Top Track Main Portion

NOTE: Top of top track = panel height plus 3" (+/- 1/4") from finished floor. Additionally, panels should overlap side walls by 1 1/2" on each side. Refer to Wall Mount form at www.rivieraglassdividers.com

- 1** Measure track and using a power miter box (chop saw) trim both main track and fascia to length as required. Allow a minimum 1 1/2" overlap on each side wall when slider is in the fully closed position. You will also want to ensure that there is enough length of track for the slider to completely clear the opening when it is in the fully open position.
- 2** Position track on the wall to allow for wall overlap when slider is in the fully closed position.
- 3** Mounting screws **MUST** be located into solid backing and spaced at approximately 24" - 32" centres including a fastener at each end of the track. Mark drill locations on the inside of the fixed fascia and drill fastener holes using the bottom drill line provided. **Tip:** To aid in track levelling drill fastener holes slightly oversized (5/16") to fit the HEX drive screws provided.
- 4** Install cushion capture and rollers into track ensuring that the roller bumper faces the cushion capture hook. Level and mount the top track to the wall above opening.

DON'T INSTALL FASCIA AT THIS TIME

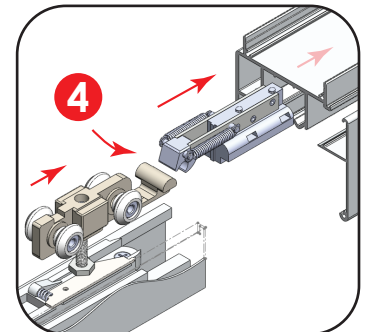
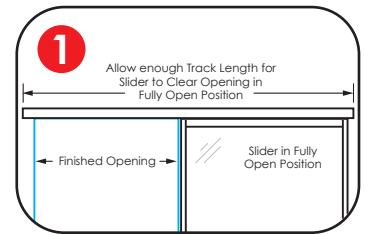
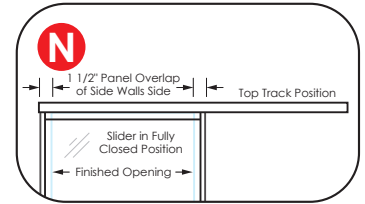

B Install Floor Post

- 5** Screw the FLOOR POST to the floor in front of the wall that the panel will slide over when open, so the leading EDGE of the post is 1/8" back from the vertical edge of the opening. The Post should be centred vertically under top roller track.
- 5.1 ALTERNATE INSTALLATION:** If it is not desirable to screw into the floor, a CARRIER POST may be wall applied. Position as above however Carrier Post **MUST** be spaced 1/2" - 5/8" away from the Top Track mounting surface by fastening the Carrier Post to the baseboard or by using shims.

IMPORTANT NOTE: Sliding Panel Rail End Cap should never come in contact with the Floor Post or Carrier Post. (See "PANEL ADJUSTMENT")

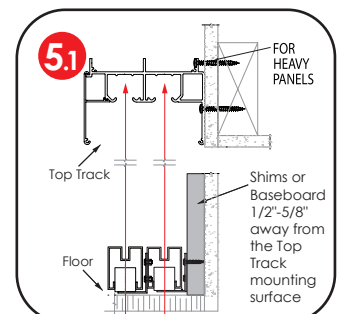
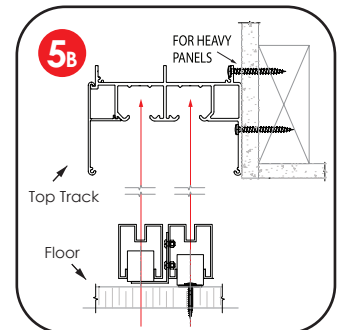
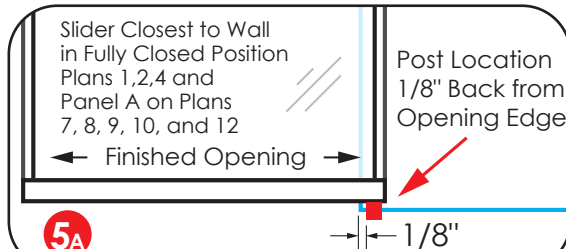

C Install Carrier Post

- 6** With short screws provided, mount the angled CARRIER POST to the outside face of Panel (A) bottom rail, in-line and flush with the panel leading edge rail cap and position vertically with the bottom of the cylindrical post 1/8" below the bottom the rail, to provide clearance for Panel (B) to slide over.

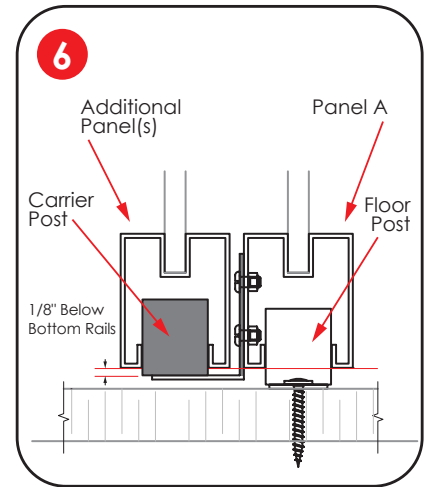
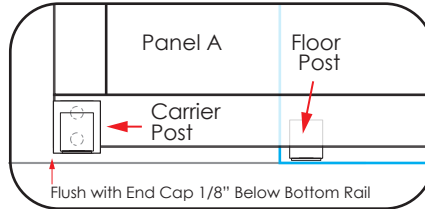

D Install the Panel

- 7** Ensure the Hanger Locks that are pre-installed in the panel rail are at the top of the panel(s).

SPECIAL NOTE: To achieve a panel stopping position in line with the end of the Cushion Capture assembly, the Roller Adjusting Bolt should engage the Hanger Lock spring 4 9/16" from the end of the panel.

- 8** Set the panel rail over the floor or carrier post(s) at the floor.
- 9** Lift the panel(s) up and engage each roller adjusting bolt head into its hanger lock by pushing bolt against spring lock until it latches. Adjust roller bolt vertically using the combination wrench/screwdriver tool provided, to adjust floor clearance and vertically align panels with wall edge.

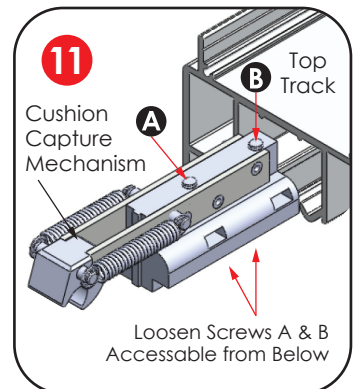
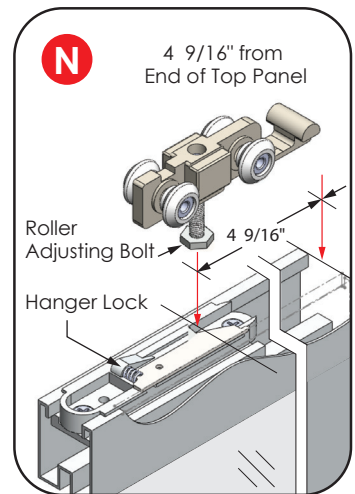

E Panel Adjustment

- 10** Adjust Cushion Capture and Hanger Lock horizontally such that the Bottom Rail Cap never comes in contact with the Floor or Carrier Posts.
- 11** Panel stopping location can be fine tuned by loosening the two screws in the cushion capture mechanism and moving to desired position along the track.
- 12** Further adjustment can be achieved by adjusting the Hanger Lock position in the top rail. Loosen the two clamp screws using an 90 degree angled Philips screw driver.
- 13** Hook removable Fascia over main track and snap into place to top track.
- 14** Install track end caps to exposed track ends with the four #4 - 1/2" screws provided, using the wrench/screwdriver tool provided. (#0-Yellow Robertson drive tip)

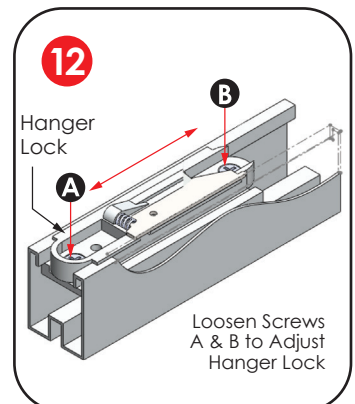

Riviera Glass Divider "Collector Blocks" are designed to assist in closing multi-panel sets of sliding door panels by collecting each panel they pass by. When closing the set, the outermost panel will inter-lock with the next panel, and pull it along to its resting position. To re-open, with all required and recommended blocks installed, pushing the outermost panel will collect all panels as a group. Panels will be staggered in the fully open position.

Below you'll find instructions for installing the blocks. Pay close attention to identify your track series (Monaco or Savona), and the correct location and orientation on the panel. Peel and stick the block in place as illustrated, then install self tapping screws to permanently secure. Pre-drilling is not necessary.

IMPORTANT: Read these instructions completely before beginning any installation.

Block Location

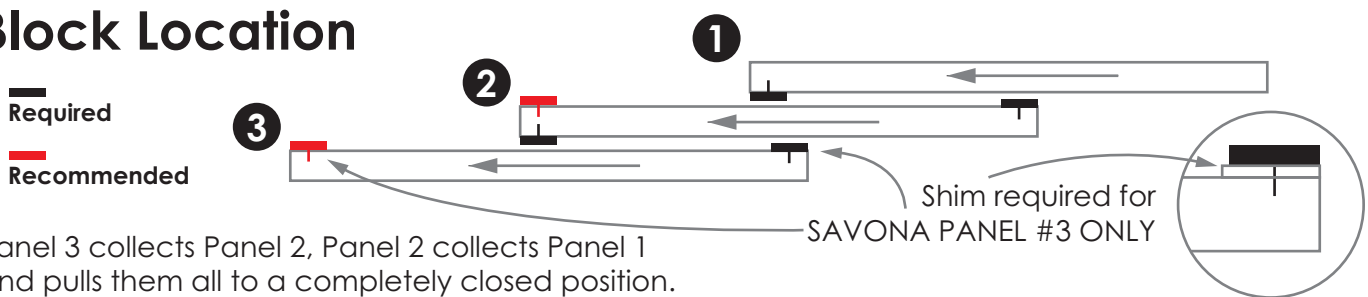

Panel 3 collects Panel 2, Panel 2 collects Panel 1 and pulls them all to a completely closed position.

Block Orientation MONACO



LONG EDGE of Block
Flush with end of Rail
@ Bottom of Rail

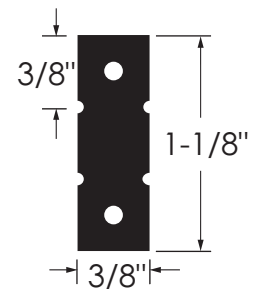
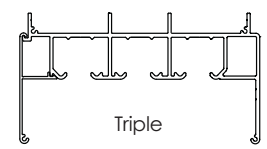
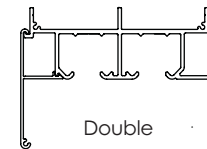
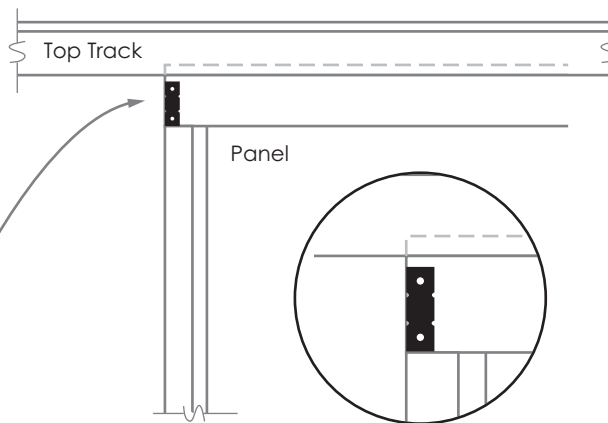

SHORT EDGE of Block
Flush with end of Rail
LONG EDGE @ Bottom
of Rail

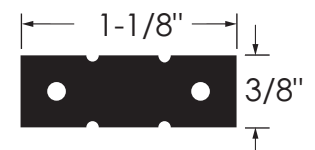
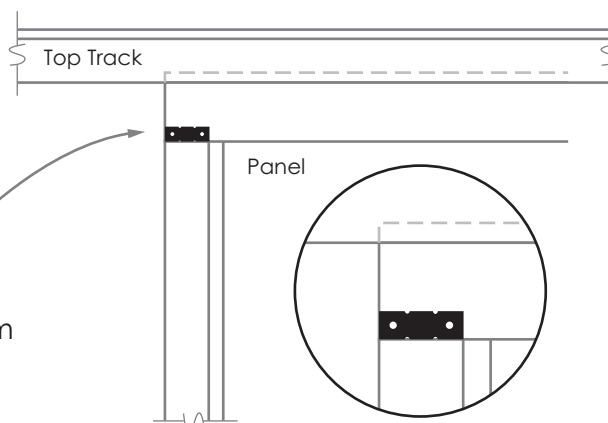

Block Orientation SAVONA

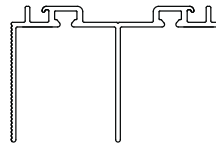

Double

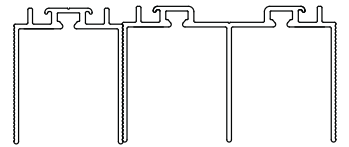

Triple



BREAK OFF BLOCK ENDS
to 3/8" x 3/8" then install
Flush with end of Rail
Bottom of Block @ bottom
of Rail... SHIM PANEL 3 ONLY

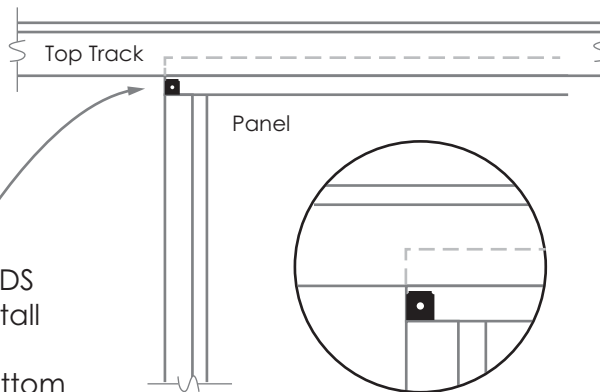

BREAK OFF at notches
to yield 2 Collector blocks
(discard middle section)

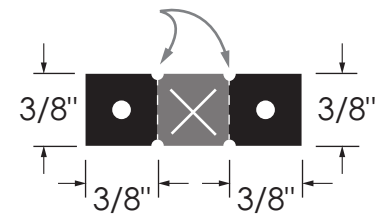

SHORT EDGE of Block
Flush with end of Rail
LONG EDGE @ Bottom
of Rail... SHIM PANEL 3 ONLY

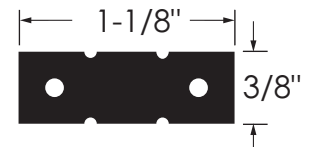
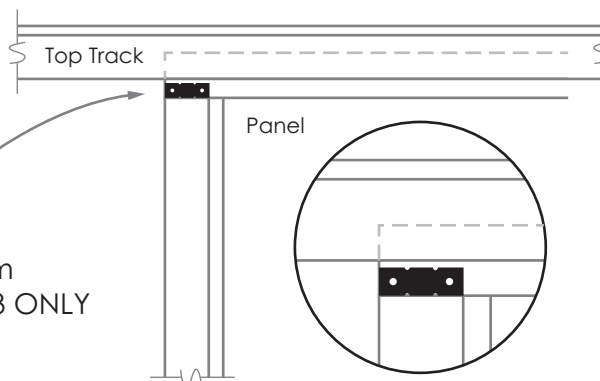

Riviera Glass Dividers are warranted to be free of defects in material and workmanship for a period of one year. Product reported as defective are subject to inspection and validation by an authorized representative. Alliance Glass Doors Inc. will repair, replace or refund the original cost of the parts, at its option. Remedies do not include glass breakage (by any cause), labour, installation costs, finishing costs, indirect or consequential damages.